



EPG Axial-Flow Submersible Pump Model AF04

October 2019

These reliable, low-maintenance storm water pumps are both economical and efficient. Axial-Flow lift provides smooth, low vibration, low pressure operation. These pumps are perfect for water quality & flood control solutions. They are equally suitable for municipal, industrial, agricultural, and aquacultural applications.

- High Volume: 50 - 550 GPM
- Low Head: 2 - 20' TDH
- Ideal for Wet Wells
- Vertical or Horizontal Styles
- Not a Trash Pump

- PUMP**
- Axial-Flow/Lift
 - Stainless Steel construction
 - Stainless Steel impeller, investment casting, dynamically balanced
 - Available in both vertical and horizontal models

- DISCHARGE:**
- 4" Diameter
 - NPT standard threading, male

- HORSEPOWER:**
- 1, 1.5, 2, 3
- 60 or 50 Hz SERVICE:**
- Single Phase or Three Phase

- VOLTAGE:**
- 200V, 230V, 460V, 575V



AF04 PUMP CURVES

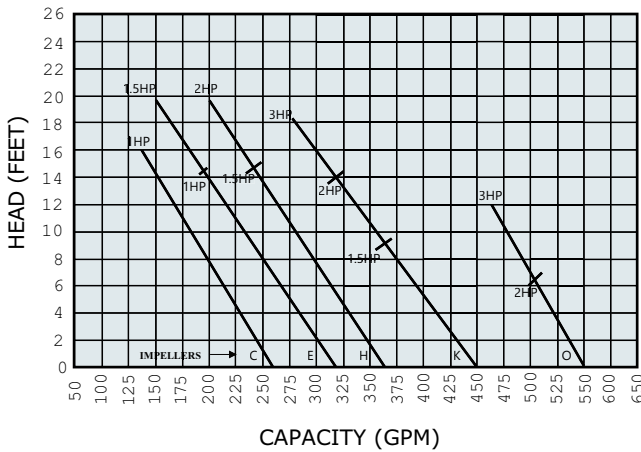

SPECIFICATIONS SUBJECT TO CHANGE WITHOUT NOTICE

VERTICAL PUMP DIMENSIONS AF04 1 PHASE

Dimensions	Weight	A-Minimum Submergence	B-Overall Height
1HP	54	16.50"	21.50"
1-1/2	59	18.50"	23"
2HP	61	20.50"	25"
3HP	77	25"	28"

AF04 3 PHASE

Dimensions	Weight	A-Minimum Submergence	B-Overall Height
1HP	60	18.50"	22"
1-1/2	60	18.50"	22"
2HP	63	20"	24"
3HP	76	22"	26"

AF04 3 PHASE WITH SCREEN

Dimensions	Weight	A- Height	B-Minimum Submergence	C-Screen Height
1HP	72	22"	18-1/2"	14-1/2"
1-1/2/2HP	72	22"	18-1/2"	14-1/2"
2HP	82	24"	20"	16-1/2"
3HP	84	26"	22"	18-3/4"

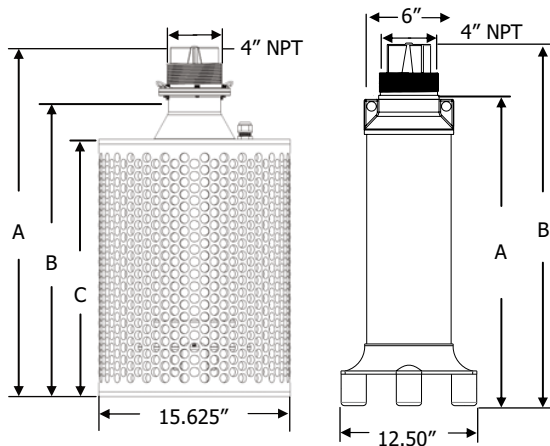

Horizontal versions available.
Optional horn intake shown.



Bulletin 9060